

Baureihe/Series/Série

Ausführung **Magnetkupplungspumpe ASME  
Blockbauweise**

**RMA-B**

Design **Magnet drive pump ASME  
Close-coupled design**



Construction **Pompe à entraînement magnétique ASME  
Construction monobloc**

**Aufstellungsplan mit NEMA-Motoren  
Outline drawing with NEMA-motor  
Cotes d' encombrement avec NEMA-moteur**

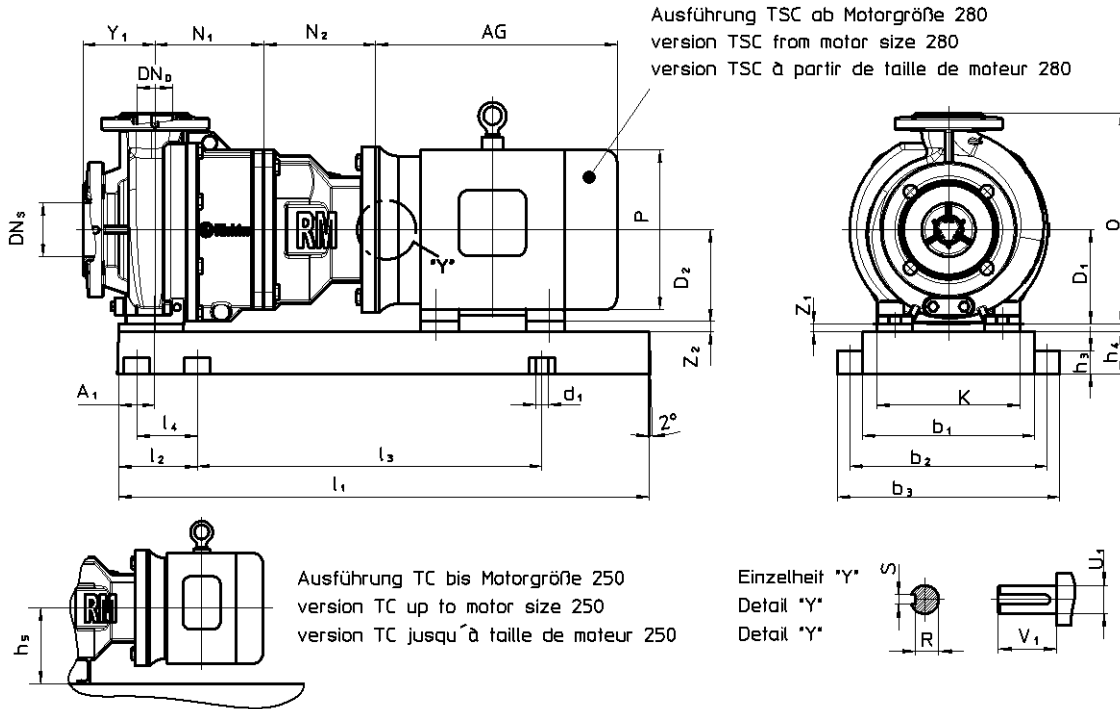

Modification techniques possibles sans préavis!  
Graphique non à l'échelle!  
Dimensions variables uniquement revêtues d'une signature!

This leaflet is subject to alteration!  
Drawing not to scale!  
Certified for construction purposes only when signed!

Technische Änderungen vorbehalten!  
Nicht maßstäblich!  
Maße nur mit Unterschrift verbindlich!

Gruppe group groupe	Pumpengröße Pump size Taille de pompe	DN <sub>s</sub> [inch] [mm]	DN <sub>D</sub> [inch] [mm]	A <sub>1</sub> [inch] [mm]	D <sub>1</sub> [inch] [mm]	K [inch] [mm]	N <sub>1</sub> [inch] [mm]	O [inch] [mm]	Y <sub>1</sub> [inch] [mm]	kg*
1	1.5"x1"x6"	1.5 (38,1)	1 (25,4)	1.97 (50)	5.25 (133)	7.97 (202,4)	6.02 (152,9)	11.75 (298)	4 (101,6)	41
	3"x1,5"x6"	3 (76,2)	1.5 (38,1)							43
	3"x2"x6"	2 (50,8)	46							
	1.5"x1"x8"	1.5 (38,1)	1 (25,4)							43,5
2	3"x1,5"x8"	3 (76,2)	1.5 (38,1)	1.97 (50)	8.25 (210)	11.7 (298)	6.69 (169,9)	16,7 (425) 17,75 (450) 19,3 (490) 17,75 (450)	4 (101,6)	65
	3"x2"x8"	2 (50,8)	70							
	4"x3"x8"	4 (101,6)	3 (76,2)							76
	3"x2"x10"	3 (76,2)	2 (50,8)							83

\* Pumpengewicht ohne Adapter, Grundplatte, Antriebshohlwelle und Motor /  
pump weight without adapter, base plate, hollow drive shaft and motor /  
Poids de la pompe sans adaptateur, socle, arbre creux d'entraînement et moteur

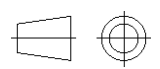

Baureihe/Series/Série

Ausführung **Magnetkupplungspumpe ASME  
Blockbauweise**

**RMA-B**

Design **Magnet drive pump ASME  
Close-coupled design**



Construction **Pompe à entraînement magnétique ASME  
Construction monobloc**

Modification techniques possibles sans préavis!  
Graphique non à l'échelle!  
Dimensions variables uniquement revêtues d'une signature!

Grundplattengröße Base plate size Taille du socle	[inch] [mm]	b <sub>1</sub> [inch] [mm]	b <sub>2</sub> [inch] [mm]	b <sub>3</sub> [inch] [mm]	d <sub>1</sub> [inch] [mm]	h <sub>3</sub> [inch] [mm]	h <sub>4</sub> [inch] [mm]	l <sub>1</sub> [inch] [mm]	l <sub>2</sub> [inch] [mm]	l <sub>3</sub> [inch] [mm]	l <sub>4</sub> [inch] [mm]	kg
<b>3 = 11.81 x 35.43 (300 x 900)</b>		11.81 (300)	13.78 (350)	15.35 (390)	0.75 (19)	1.38 (35)	2.56 (65)	35.43 (900)	5.9 (150)	23.62 (600)	3.54 (90)	37
<b>4 = 13.84 x 39.37 (340 x 1000)</b>		13.84 (340)	15.75 (400)	17.72 (450)	0.95 (24)	1.57 (40)	3.15 (80)	39.37 (1000)	6.69 (170)	25.98 (660)	4.33 (110)	55
<b>5 = 14.96 x 44.09 (380 x 1120)</b>		14.96 (380)	17.32 (440)	19.29 (490)				44.09 (1120)	7.48 (190)	29.13 (740)	5.12 (130)	72
<b>6 = 16.93 x 49.21 (430 x 1250)</b>		16.93 (430)	19.29 (490)	21.26 (540)				49.21 (1250)	8.07 (205)	33.07 (840)	5.31 (135)	93
<b>7 = 18.9 x 55.12 (480 x 1400)</b>		18.9 (480)	21.65 (550)	24.02 (610)	1.1 (28)	1.97 (50)	3.94 (100)	55.12 (1400)	9.06 (230)	37.01 (940)	6.3 (160)	120
<b>8 = 20.87 x 63 (530 x 1600)</b>		20.87 (530)	23.62 (600)	25.98 (660)				63 (1600)	10.63 (270)	41.73 (1060)	7.09 (180)	192

This leaflet is subject to alteration!  
Drawing not to scale!  
Certified for construction purposes only when signed!

	Pumpe pump pompe	Adapter adapter adaptateur	Motor motor moteur	Grundplatte base plate socle	Σ
<b>Maße dimensions dimensions</b>	Z <sub>1</sub>		Z <sub>2</sub>		L
<b>Gewichte weights poids</b>	kg	kg	kg	kg	kg

Technische Änderungen vorbehalten!  
Nicht maßstäblich!  
Maße nur mit Unterschrift verbindlich!

Gruppe group groupe	Motorbaugröße / motor size / taille de moteur															
	143 T	145 T	182 T	184 T	213 T	215 T	254 T	256 T	284 TS	286 TS	324 TS	326 TS	364 TS	365 TS	404 TS	405 TS
<b>1</b>	2								5	6	-					
<b>2</b>	-	3							5	6	7	8				

Baureihe/Series/Série

Ausführung

**Magnetkupplungspumpe ASME  
Blockbauweise**

**RMA-B**

Design

**Magnet drive pump ASME  
Close-coupled design**



Construction

**Pompe à entraînement magnétique ASME  
Construction monobloc**

Motorabmessung  
Motor dimension  
Dimensions moteur

NEMA-Motor NEMA-motor NEMA-moteur	D <sub>2</sub> [inch] (mm)	AG** [inch] (mm)	P [inch] (mm)	R [inch] (mm)	S [inch] (mm)	U <sub>1</sub> [inch] (mm)	V <sub>1</sub> [inch] (mm)
140 TC	3,5 (88,9)	14.37 (365)	7.28 (185)	0,77 (19,6)	0,19 (4,78)	0,875 (22,23)	2,25 (57,15)
180 TC	4.5 (114,3)	13.77 (350)	9.25 (235)	0,97 (25)	0,25 (6,35)	1,125 (28,58)	2,75 (69,85)
210 TC	5.25 (133,4)	16.88 (429)	10.51 (267)	1,2 (30,5)	0,312 (7,92)	1,375 (34,93)	3,38 (85,85)
250 TC	6.25 (158,8)	21.3 (541)	13.22 (336)	1,42 (35,97)	0,375 (9,53)	1,625 (41,28)	4 (101,6)
280 TSC	7 (177,8)	23.07 (586)	14.88 (378)	1,59 (40,4)	0,5 (12,7)	1,875 (47,63)	3,25 (82,55)
320 TSC	8 (203,2)	25.43 (646)	17 (432)	1,59 (40,4)	0,5 (12,7)	1,875 (47,63)	3,75 (95,25)
360 TSC	9 (228,6)	28.3 (719)	17.7 (449)	1,59 (40,4)	0,5 (12,7)	2,125 (53,98)	4,25 (107,95)
400 TSC	10 (254)	32.2 (817)	19.5 (497)	1,85 (46,86)	0,5 (12,7)	2,125 (53,98)	4,25 (107,95)

\*\* ca. Maße gemäß Siemens /  
approx. dimensions acc. Siemens /  
comme a peu près les dimensions de siemens

Adapterabmessung  
Adapter dimension  
Dimensions adaptateur

Gruppe group groupe	NEMA-Motor NEMA-motor NEMA-moteur	N <sub>2</sub> [inch] (mm)	h <sub>5</sub> [inch] (mm)	kg***	
1	140 TC *	4.52 (114,9)	5.25 (133)	8,5	
	180 TC*	5.71 (145)		13	
	210 TC*	6.34 (161)	-	14,5	
	250 TC*	5.71 (145)		15	
	280 TSC	6.1 (155)		16,5	
	2	180 TC*	7.22 (183,5)	8.25 (210)	13
		210 TC*			13,5
250 TC*		-		19,5	
280 TSC			7.5 (190,5)	23,5	
320 TSC				-	24
360 TSC					
400 TSC					

\* mit Stützfuß  
\* with support bracket  
\* avec patte de support

\*\*\* beinhaltet Gewicht der Antriebshohlwelle  
\*\*\* includes weight of hollow drive shaft  
\*\*\* comprend le poids du arbre creux d'entraînement

**Stutzenkräfte / nozzle forces / force admissible**

gemäß HI 9.6.2 / according to HI 9.6.2 / selon HI 9.6.2

Modification techniques possibles sans préavis!  
Graphique non à l'échelle!  
Dimensions variables uniquement revêtues d'une signature!

This leaflet is subject to alteration!  
Drawing not to scale!  
Certified for construction purposes only when signed!

Technische Änderungen vorbehalten!  
Nicht maßstäblich!  
Maße nur mit Unterschrift verbindlich!