

Richter PFA/PTFE Lined Safety Relief Valves

KSEA



ASME Section VIII,
Div.1/National Board certified
ASME Class 150 RF flanges
PTFE balanced bellows
Compatible with most
API 526 face to centerline
dimensions



Applications

Overpressure protection for unfired pressure vessels and plant systems used with corrosive and high purity liquids, gases and vapors.

Examples:

- Reactors in API plants
- Low pressure chlorine cells
- Metal-sensitive fluids (H₂O₂, electrograde chemicals etc.)
- Highly corrosion resistant and chemically inert with certification for vapors, gases and liquids
 - More economical choice compared to high alloy valves: lower spare part cost, typically shorter lead time, quicker delivery
 - More reliable performance in corrosive service
 - Alternative to high alloy or composite rupture discs
- Other fluids incl. HCl, H₂SO₄, NaOH, CH₃COOH, HF, Cl₂, HBr, N₂ etc. and halogens
- Applications where metallic valves do not provide longterm operation between inspection or replacement intervals

Operating range

- -20 °F (-29 °C) to 356 °F (180 °C)
- Set pressures 1.45-188 psig (0.1-13 barg) depending on sizes/materials. Details see page 3.
- **New:** Option 300 lbs inlet flange, from PFA-lined ISA-105 carbon steel, for set pressures to 188 psig (13 barg)

Product features and benefits

- Reliable and practice proven design
- High discharge coefficient for high flow capacities
- Standardized design with price and lead time advantage over valves made of Hastelloy, titanium etc.
- Reseats and shuts off the pipeline after operation, contrary to rupture discs
- Certification covers liquids, gases and vapors

Type code

lining PFA/PTFE KSEA/F...
 inlet/outlet size ... /_

- ① **PTFE balanced bellows for hermetic seal to valve bonnet and atmosphere**
 - Protects valve stem against corrosion, optionally Hastelloy C stem, guide etc. for extremely permeating fluids like chlorine and bromine chemicals
 - Positioned outside the flow
 - Pressure balanced design to counteract the effects of superimposed (constant and variable) and built-up back pressures
 - Axial needle roller cage in upper spring plate: no twisting of bellows when setting the adjusting screw

- ③ **External corrosion protection**
 - Epoxy coating
 - Stainless steel fastening hardware

- ④ **Lifting lever**
 - Position prevents from unwanted actuation
 - Lift indicator option by proximity switch signal transmitter, details on request

- ⑤ **Metal to metal bearing surfaces**
 - Ensures precise guidance of the stem, constant travel and repeatable performance

- ⑥ **Robust SA-395 ductile iron body**
 - Absorbs flow forces, system pressure and piping loads
 - Divergent outlet: condensate drains

- ⑦ **Interchangeable nozzle (seat) and disc (plug)**
 - Pressure resistant PTFE-carbon compound (no glass or ceramics)
 - Optional available in modified pure TFM-PTFE, Hastelloy etc.

- ② **Thick walled PFA/PTFE lining of the complete valve body**
 - Universally corrosion resistant
 - Vacuum proof
 - High permeation resistance

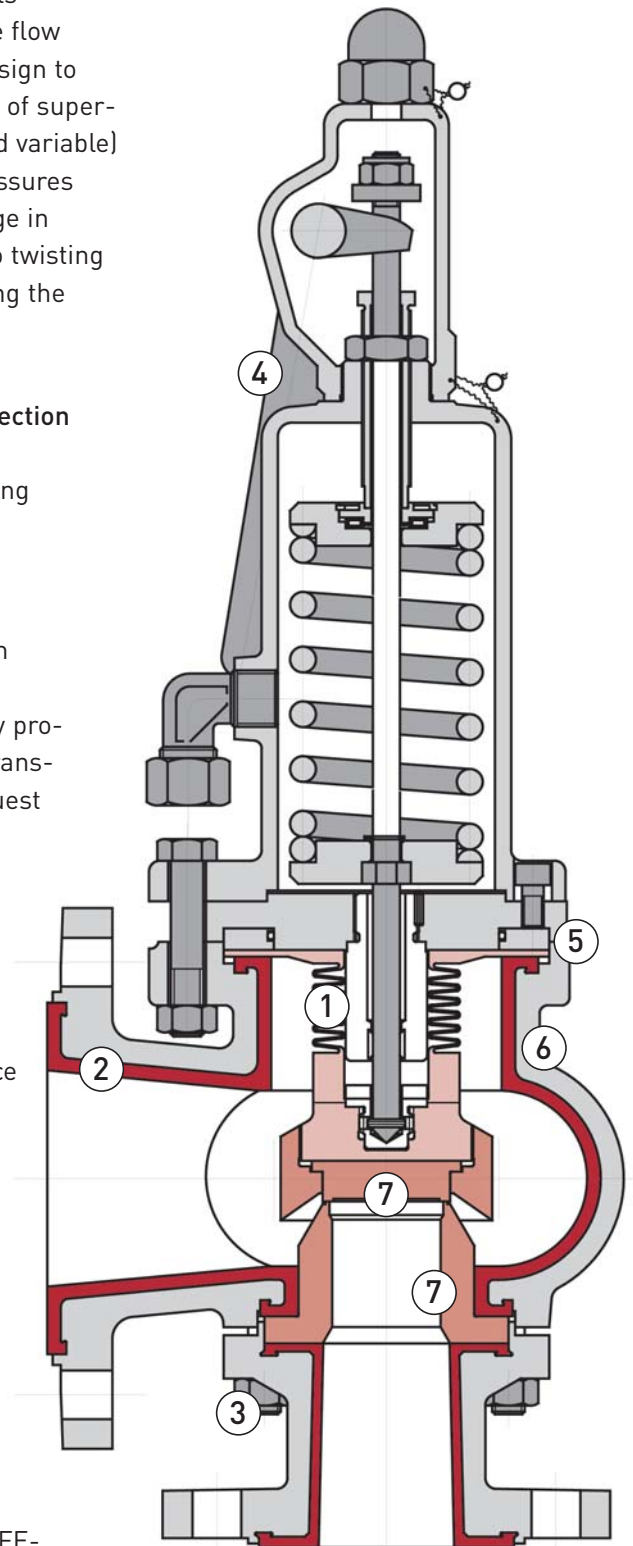

Operating range, capacities, pressure/temperature diagram

Set pressure ranges

Valve size inlet/outlet	Certified set pressure range psig (barg)*
KSEA 1 1/2"	3.62 - 188 (0.25 - 13)
KSEA 2 2/3"	1.45 - 188 (0.1 - 13)
KSEA 3 3/4"	1.45 - 145 (0.1 - 10)
KSEA 4 3/4"	1.45 - 145 (0.1 - 10)

* Set pressures below 15 psig (1.034 barg) do not require ASME certification, thus without ASME UV stamp

Consult with manufacturer for set pressures above 188 psig (13 barg) for 1 1/2" and 2 2/3" & 145 psig (10 barg) for 3 3/4" and 4 3/4"



ASME/National Board certified discharge coefficients K = (KD x 0.9)

Valve size	Flow dia. d ₀		Flow area A ₀		Valve lift		Vapors/gases K	Liquids K
	inch	mm	sq. in.	mm ²	inch	mm		
KSEA 1 1/2"	0.866	22	0.589	380	0.276	7	0.841	0.563
KSEA 2 2/3"	1.575	40	1.948	1257	0.512	13	0.841	0.542
KSEA 3 3/4"	1.969	50	3.045	1964	0.630	16	0.841	0.542
KSEA 4 3/4"	3.150	80	7.793	5027	1.024	26	0.841	0.542

The KSEA safety relief valves can be closely adapted to the required discharge capacity by means of lift limitation.

Discharge capacities at 10 % overpressure for air (60 °F/14.7 psia, 15.6 °C/1.01 bara) and water (68 °F, 20 °C)

Set pressure psig	KSEA 1 1/2"		KSEA 2 2/3"		KSEA 3 3/4"		KSEA 4 3/4"	
	air scfm	water gpm	air scfm	water gpm	air scfm	water gpm	air scfm	water gpm
5	206.4	35.6	682.5	113.5	1066.8	177.4	2730.2	454.0
10	251.8	45.4	832.8	144.7	1301.8	226.1	3331.6	578.7
15	297.3	53.5	983.1	170.2	1536.7	266.1	3933.0	681.0
20	342.7	60.4	1133.4	192.4	1771.7	300.8	4534.3	769.8
30	433.6	72.4	1434.1	230.5	2241.7	360.3	5737.1	922.0
40	533.6	83.6	1764.8	266.1	2758.6	416.0	7060.1	1064.7
50	633.6	93.5	2095.5	297.5	3275.6	465.1	8383.1	1190.3
60	733.6	102.4	2426.2	325.9	3792.5	509.5	9706.1	1303.9
70	833.6	110.6	2756.9	352.1	4309.5	550.3	11029.1	1408.4
80	933.6	118.2	3087.6	376.4	4826.4	588.3	12352.2	1505.7
90	1033.6	125.4	3418.4	399.2	5343.4	624.0	13675.2	1597.0
100	1133.6	132.2	3749.1	420.8	5860.3	657.8	14998.2	1683.4
110	1233.6	138.6	4079.8	441.3	6377.3	689.9	16321.2	1765.6
120	1333.6	144.8	4410.5	461.0	6894.2	720.5	17644.2	1844.1
130	1433.6	150.7	4741.2	479.8	7411.2	750.0	18967.2	1919.4
140	1533.6	156.4	5071.9	497.9	7928.1	778.3	20290.3	1991.8
150	1633.5	161.9	5402.6	515.4	8445.1	805.6	21613.3	2061.7
160	1733.5	167.2	5733.3	532.3	8962.0	832.0	22936.3	2129.3
170	1833.5	172.3	6064.0	548.6				
180	1933.5	177.3	6394.8	564.6				
190	2033.5	182.2	6725.5	580.0				

scfm = standard cubic feet per minute; gpm = U.S. gallon per minute

ASME = American Society of Mechanical Engineers
 National Board = National Board of Boiler and Pressure Vessel Inspectors
 Richter = TM Richter Chemie-Technik GmbH
 Viton = TM DuPont

Materials, dimensions, weights

Components and materials

Item	Designation	Standard design	Available on request
100	Body	Ductile iron SA-395/PTFE	Antistatic PTFE
117	Thrust flange	Carbon steel 420 [1.0460]	Stainless steel 304 [1.4301]
122	Inlet nozzle	Ductile iron SA-395 /PFA (Cl. 150)	Antistatic PFA, carbon steel ISA-105/PFA (for Cl.300)
124	Pressure ring	Stainless steel 304 [1.4301]	
204	Disc (plug)	PTFE-carbon 25 %	Pure PTFE
205	Nozzle (seat)	PTFE-carbon 25 %	Pure PTFE, Hast. C, titanium
206	Bellows	Modified PTFE	
237	Disc holder (lifting aid)	PTFE-carbon 25 %	
238	Lifting lever	Ductile iron A-395 [0.7043]	
305	Bearing guide	Carbon steel A570 Gr.36 [1.0037]	Hastelloy C
306	Stem guide	Stainless steel 304 [1.4301]	Hastelloy C
307/1	Bearing bush	PTFE-carbon 25 %	
308	Insert sleeve	Stainless steel 304 [1.4301]	Hastelloy C
395	Axial needle roller cage		
396	Axial washer		
400/x	O-Ring	FKM (e.g. Viton®)	
420	Thrust ring, split	Carbon steel A570 Gr.36 [1.0037]	Stainless steel, Hastelloy C
508	Travel stop*	Stainless steel 304 [1.4301]	Hastelloy C
513	Spring bonnet	Ductile iron SA-395	
534	Stem nut	Carbon steel A570 Gr.50 [1.0052]	
535	Lifting cap	Ductile iron SA-395	
536	Upper spring plate (washer)	Stainless steel 304 [1.4301]	
537	Lower spring plate (washer)	Stainless steel 304 [1.4301]	
538	Adjusting screw	Stainless steel 304 [1.4301]	Hastelloy C
539/x	Locking plate, not shown	Stainless steel 304 [1.4301]	
561/1	Grooved pin	Carbon steel	
802	Spindle	Stainless steel 430F [1.4104]	Hastelloy C
901/x	Hex. screw	Stainless steel SA-193 B8	Chromium-molybdenum B7
902/1	Stud screw	Stainless steel SA-193 B8	Chromium-molybdenum B7
914/1	Hex. socket screw	Stainless steel SA-193 B8	Chromium-molybdenum B7
915	Elbow fitting	Stainless steel A-121 [1.4541]	
920/1+2	Hex. nut	Stainless steel SA-194 B8	Chromium-molybdenum B7
920/3	Hex. nut	Carbon steel A570 Gr.33 [1.0111]	
927/1	Cap nut	Stainless steel 304 [1.4301]	
929/1	Prev. torque type hex. nut	Carbon steel, galvanized	
932/x	Snap ring	Spring steel	
935/1	Lead seal	Plastics	
939/x	Spring type slotted pin	Stainless steel 304 [1.4301]	
952/1	Pressure spring	EN 10270-1-SH, galvanized	
w/o no.	Flange protection caps	PE - plastic, not shown	

* only valves with lift limitation

KSEA dimensions and weights

Valve size	A		B		H		Weight	
	inch	mm	inch	mm	inch	mm	lbs	kg
1" / 2"	4.125	104.7	3.937	100	13.98	355	33	15
2" / 3"	5.375	136.5	4.921	125	17.12	435	55	25
3" / 4"	6.100	155.0	6.100	155	20.67	525	88	40
4" / 6"	8.661	220.0	7.874	200	27.95	710	187	85

Flange connections to ANSI B16.5, Class 150

* Note: This table shows the API 526 dimensions and suits to compare with the KSEA face to centerline dimensions

API 526 dimensions*

A to API 526	B to API 526		
		inch	mm
4.125	104.7	4.5	114.3
5.375	136.5	4.875	123.8
6.125	155.6	6.375	161.9
7.75	196.8	8.25	209.5

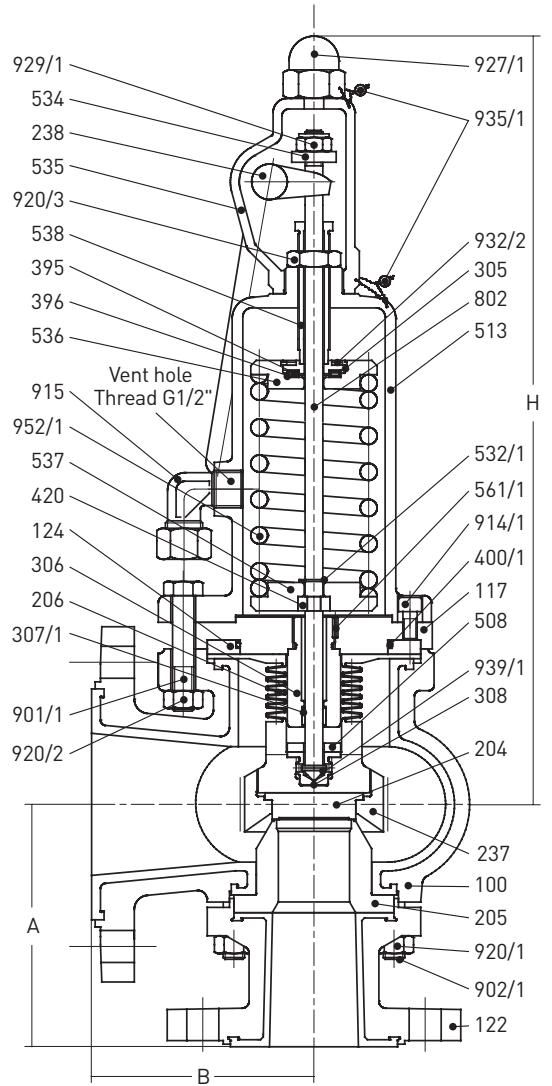

Presented by:

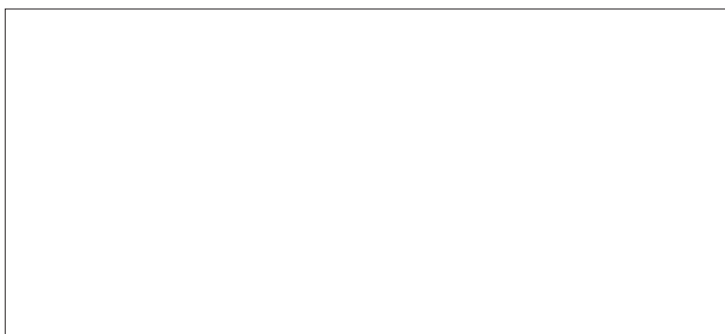

Richter Chemie-Technik GmbH
 Otto-Schott-Str. 2
 D-47906 Kempen, Germany
 Tel. +49 (0) 21 52/146-0
 Fax +49 (0) 21 52/146-190
 richter-info@richter-ct.com
 www.richter-ct.com